

Background

The EUROTRANS project is an integrated project in the 6th European Framework Program in the context of Partitioning and Transmutation (P&T). The objective of this project is the step-wise approach to a European Transmutation Demonstration. This project aims to deliver an advanced design of a small-scale Accelerator Driven System (ADS), XT-ADS, as well as the conceptual design of a European Facility for Industrial Transmutation, EFIT. The partners of this project accepted to use the MYRRHA "Draft-2" design file as a starting basis for the design of the short-term XT-ADS demonstration machine. Instead of starting from a blank page, this allowed optimising an existing design towards the needs of XT-ADS, and within the limits of safety requirements. Many options have been revisited and the framework is now set up.

Objectives

While our MYRRHA "Draft-2" design file was still a *conceptual* design, our intention is to get at the end of the EUROTRANS project (March 2009) an *advanced* design of the XT-ADS machine, albeit a first advanced design. Moreover, industrial partners (Ansaldo Nucleare, Areva) will contribute to this XT-ADS design.

Principal results

An ADS consists of the coupling of three components: an *accelerator* delivers a proton beam on a *spallation target* installed inside a *sub-critical core*. The reference accelerator for XT-ADS has a 600 MeV x 2.5 mA proton beam while it was limited to 350 MeV x 5 mA for MYRRHA, the latter value being however kept as backup option. The core inlet and outlet temperature were significantly increased and reach now 300°C (inlet) and 400°C (outlet). On the demand of the safety work package, the fuel power density was limited to 700 W/cm³, while it reached 1000 W/cm³ for MYRRHA. The thermal power of the installation should originally range between 50 and 70 MW_{th}.

As in MYRRHA, the XT-ADS is designed to use MOX as fuel material; the fuel pin and fuel assembly design, as well as the primary neutronic calculations, are described in another section of the present scientific report. The design of the XT-ADS spallation target also started from the MYRRHA design taking the modifications mentioned above about accelerator, fuel and core. If some topics should in principle facilitate the design (using larger fuel assemblies implies more room for the target, lower energy deposited by the 600 MeV proton beam), such a design requires quite a lot of R&D effort.

For the vessel configuration including the primary systems, we have also started from the MYRRHA design and we have included some enhancements suggested by the partners.

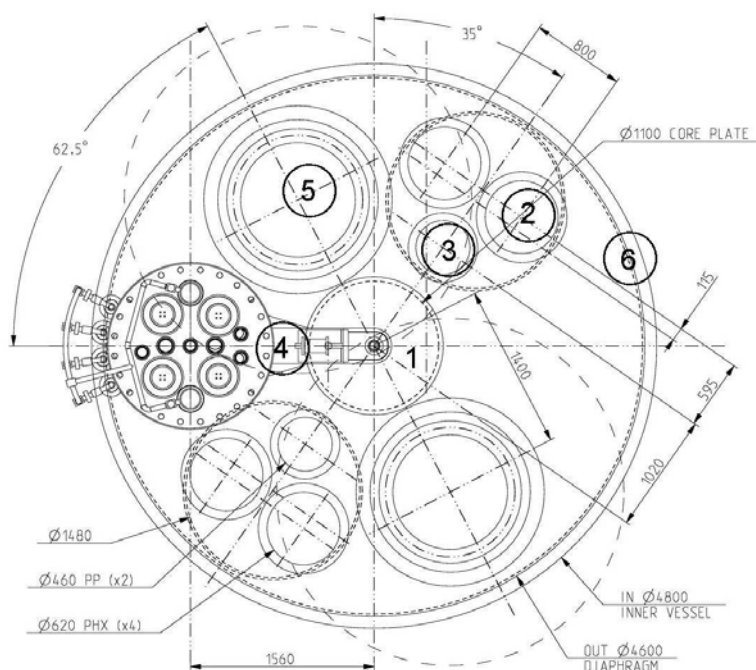

XT-ADS cross section of the vessel

As shown on the picture left, the number of primary components was kept as low as possible to minimize the machine cost and maintenance without jeopardizing safety functions and availability; a comparison exercise was performed and the final chosen configuration contains two groups of each one primary pump and two heat exchangers (MYRRHA had four groups, each of one pump and two heat exchangers).

The heat exchangers have been designed to evacuate a total of 70 MW_{th} (instead of a total of 60 MW_{th} for MYRRHA). The 70 MW_{th} value takes into account not only the core, but also the spallation target, the decay heat from the fuel storage and some other minor heat sources.

The present XT-ADS design differs quite a lot from the MYRRHA design when we look at the vertical section shown left:

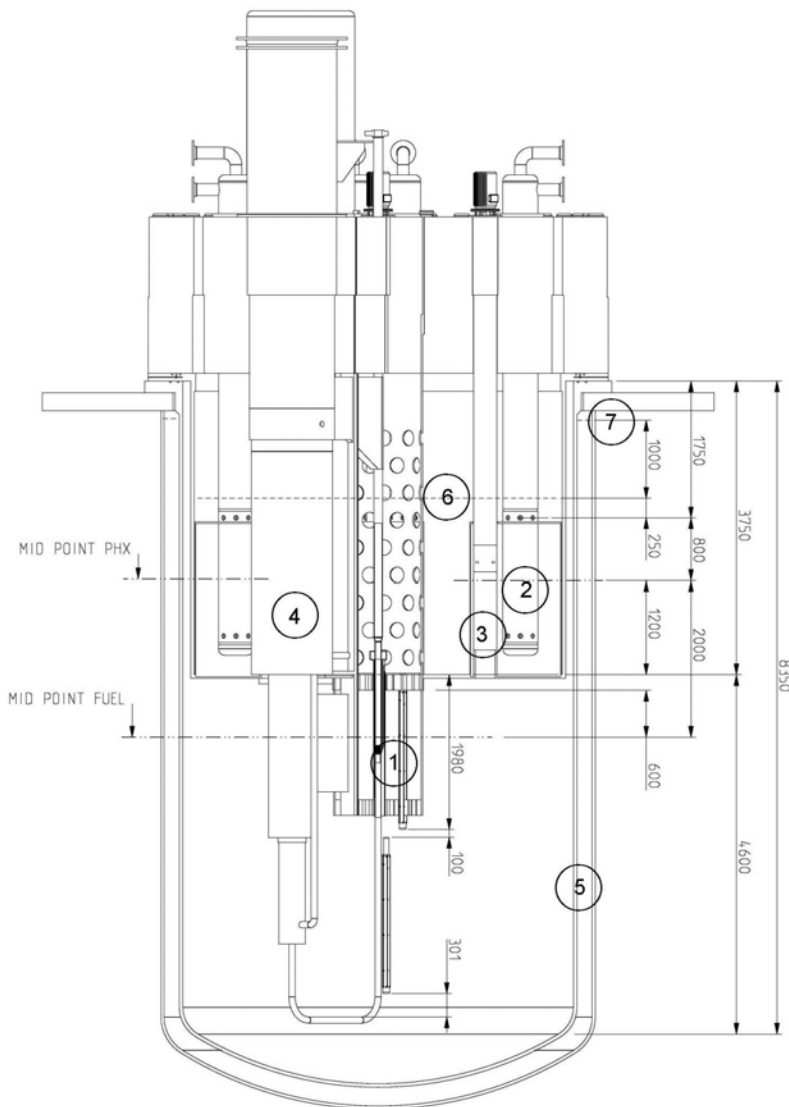

- the vessel has now an elliptical bottom;
- and is hanging (while MYRRHA was standing);
- "reactor vessel cooling system" (probably by natural circulation of air) is used as ultimate decay heat removal;
- a large part of the work has been devoted to the fuel loading; if the MYRRHA option (loading from the bottom) is far from the classical options in reactor technology, it was still preferred over a fuel loading from the top, due to the interferences with the installation, also from the top, of experiments;
- the lead-bismuth eutectic in the vessel has two free levels (see figure); the level difference corresponds to the core pressure drop;
- the elevation difference between core and primary heat exchangers has increased;
- the core hydraulic resistance has been improved; these two last measures enhance natural circulation in case of emergency situations.

XT-ADS vertical section of the vessel

Future work

The framework for XT-ADS design has been set up. The future work, until March 2009, end of the EUROTRANS project, consists of detailed calculations of every component of the XT-ADS machine. The main partners (SCK•CEN, Ansaldo, Areva) are sharing the work to be performed. SCK•CEN will be in charge of the primary systems (including the reactor main cooling system, the reactor vessel and cover) and of the in-service inspection and repair studies.

Main contact person

Didier De Bruyn, didier.de.bruyn@sckcen.be

Main reference

D. De Bruyn, D. Maes, P. Schuurmans, G. Van den Eynde, H. Ait Abderrahim (2006) "Status of the ADS Research & Development and of the related technology in Belgium: the evolution of the MYRRHA project", IAEA Technical Meeting "Review of the Status of Accelerator Driven Systems R&D and Technology", Vienna (Austria), December 4-6, 2006