

Background

Concerns about clean air and global warming led car manufacturers to develop hybrid cars. A few models already reached the market but the manufacturers anticipate that the production figure will hit the million mark at the horizon 2010. Hybrid cars make an extensive use of power electronics, which implies – relatively - large size semi-conductor components. The initial doping of those components is best made by neutron irradiation, which achieves a better doping uniformity than chemical processes. Silicon doping becomes therefore a growing market for a number of research reactors, in supplement to their medical isotopes productions.

With the SIDONIE facility in operation since 1992, the doping of silicon is not a new activity in the BR2 reactor. However, SIDONIE is limited to 5" diameter ingots whereas the trend is to 6" and 8" diameter or even 12".

Objectives

The purpose of POSEIDON (POol Side Equipment for Irradiation and DOPing of silicon by Neutrons) is to allow the large scale irradiation of 6" and 8" diameter silicon ingots.

Principal results

Adequate doping conditions are met when silicon ingots are irradiated in a thermal neutron flux, with as little fast flux component as possible. In addition, the neutron and gamma fluxes should not be too important in order to avoid too much heat generation in the ingot. These conditions can be produced in the BR2 reactor by using a large block consisting of a neutron moderator. This will be located in the reactor pool close to the BR2 vessel at core level. Due to the particular shape of the BR2 vessel – a hyperboloid – this irradiation position is not easy to access.

Therefore, the large block that is referred to as the POSEIDON facility, is penetrated by six irradiation channels hanging like a pendulum at the working floor in the BR2 pool. In the loading position (vertical) it is clear of obstacles above, like the reactor top cover. In the irradiation position, it is pushed against the vessel by a system installed in the pool.

The six irradiation positions are each sized for the irradiation of 8" ingots, loaded in baskets. Two ingots are stacked up in each position. The doping of 6" ingots will be performed in the same positions using special adaptors to fill the gap.

The radial flux gradient will be compensated by the rotation of the ingots during the irradiation. The axial flux gradient will be compensated by switching the positions of the upper and lower ingot at mid-irradiation.

The production capacity of POSEIDON is very much influenced by the target resistivity required by the customer (the lower the resistivity, the longer the irradiation duration).

With the very high production rate that is anticipated, considerable effort is devoted to handling systems: assistance is needed for the loading of the irradiation baskets (an 8" ingot weighs 18 kg), for the switching of upper and lower ingot, for the storage before, during and after irradiation, for the recovery of the ingots, their decontamination, control and packaging before shipping.

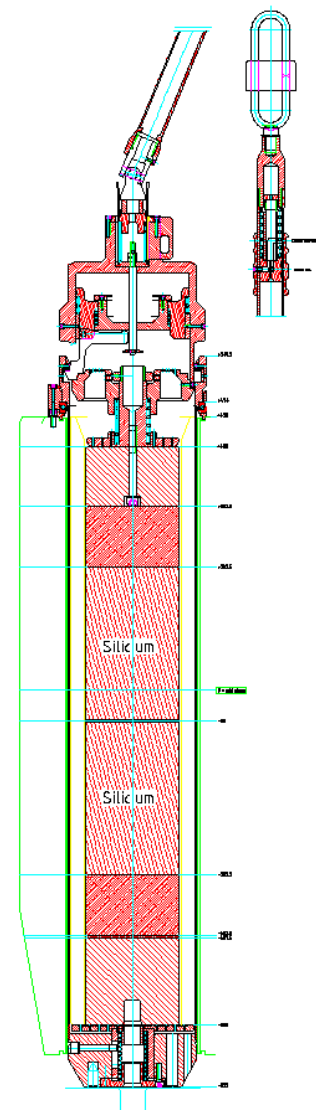

POSEIDON
irradiation basket

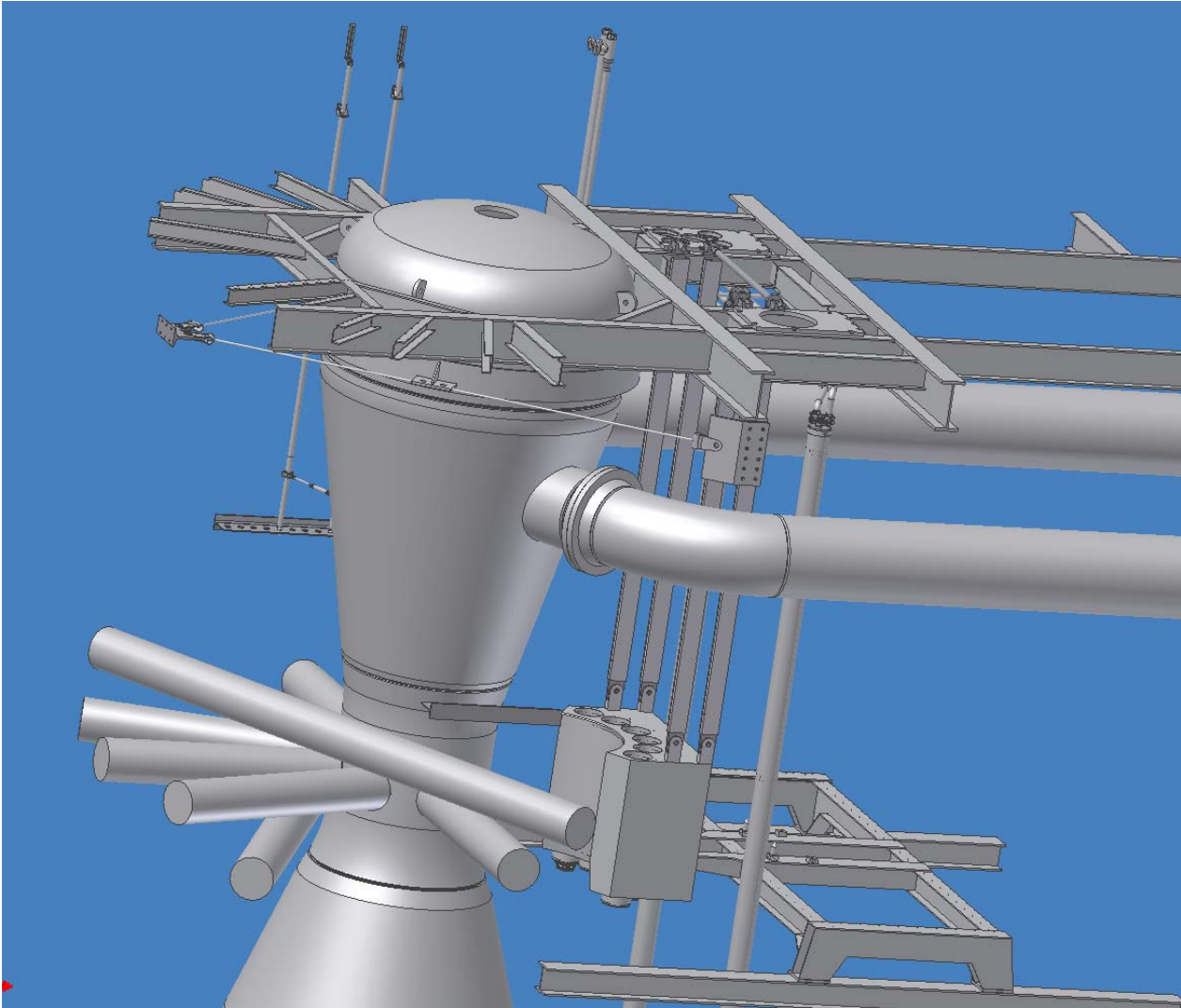

BR2 vessel and POSEIDON irradiation block in the loading position

2007 was a very busy year. The procurement of the components proved to be more difficult than anticipated. Nevertheless, at the end of 2007, all large components of the irradiation system were delivered at SCK•CEN by their suppliers and installed in the test pit.

The complexity of the ancillary systems, required for the handling of ingots before, during and after the irradiation, grew to become a little production plant in itself.

Future work

The final assembly of the components in BR2 will be performed begin 2008 and the first qualification irradiation is foreseen in the first half of 2008.

Main contact person

Philippe Benoit, philippe.benoit@sckcen.be